

U 500

(Universal Welding Device U 500)

PIPE ROTATOR WITH CLAMPING ROLLER SYSTEM (patented) The welding device especially designed for pipe welding

Technical data U 500:

Rotary speed: infinitely variable 0 - 130 cm/min. Pipe range with clamped pipe: 20 - 200 mm incl. component flange. Pipe range with unclamped pipe: 20 - approx. 300 mm (after take out the holding column). Max. tilting moment in relation to axis of tilt: 1500 cmkg. Max. load (horizontal): 300kg on each rotator and roller support frame. Max. load (vertical): 150 kg. Torque at drive roller: 500 cmkg. Power requirement: approx. 500 VA, 230 V, 1ph. (other voltage possible).

– We reserve the right to alter specifications without prior notice. –

Accessories for U 500:

- No. 502 roller support frame to support longer pipes, height adjustable.
- No. 502a set of rubber coated rollers for idler roller.
- No. 504 flangeplate 500 i.d. to convert the machine into a welding turntable.
- No. 505 holding attachment for a torch (with or without double slide), to be fixed on the pipe rotator. Designed for oxyacetylene cutting and bevelling of pipes as well as for automatic welding of round joints.
- No. 506 clamping attachment to weld together pipe bends and pipes with elbows (Only in connection with No. 504.) Clamping range 80 - 200 mm.
- No. 507 1 set of clamps, 4, 5, 6, 8, 10, 12, 14, 16 inches, For precise axial location during oxyacetylene cutting.
- No. 507a The same set of clamps in stainless steel.
- No. 508 1 set of rubber coated rollers. For stainless steel, non ferrous and plastic pipes.
- No. 508a set of rubber coated rollers for lobster backs.
- No. 509 set of rollers, usable for stainless steel pipes **and** stainless steel flanges (material of rollers: stainless steel).
- No. 510 grinding accessory for grinding of weld bevels (only in connection with accessory No. 507). Includes jig, adjustable to multiple angels, support and angle grinder.



Pipe rotator **Model U 500** (for clamping, rotation and tilting), version B.
This version has an adjustable clamping arm.
The clamping is carried out by an adjustable clamping spindle.
Further technical data are the same as for model U 500, version A (with cotter pin).

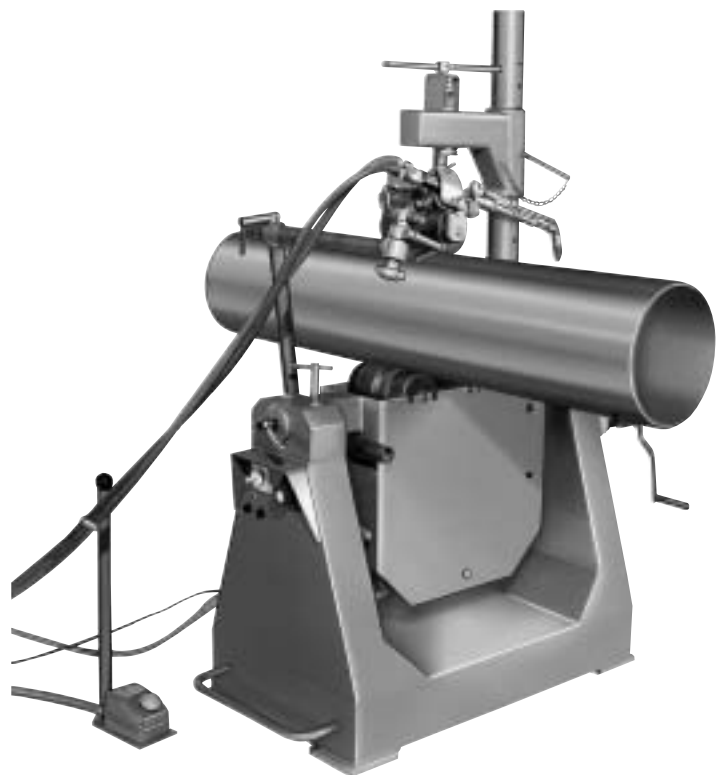

U 500 A with cutting torch holder. Oxyacetylene cutting of a pipe.

U 1000 / U 1000 H

(Universal welding device U 1000 / U 1000 H)

PIPE ROTATORS WITH CLAMPING ROLLER SYSTEM (patented)

The welding device especially designed for pipe welding

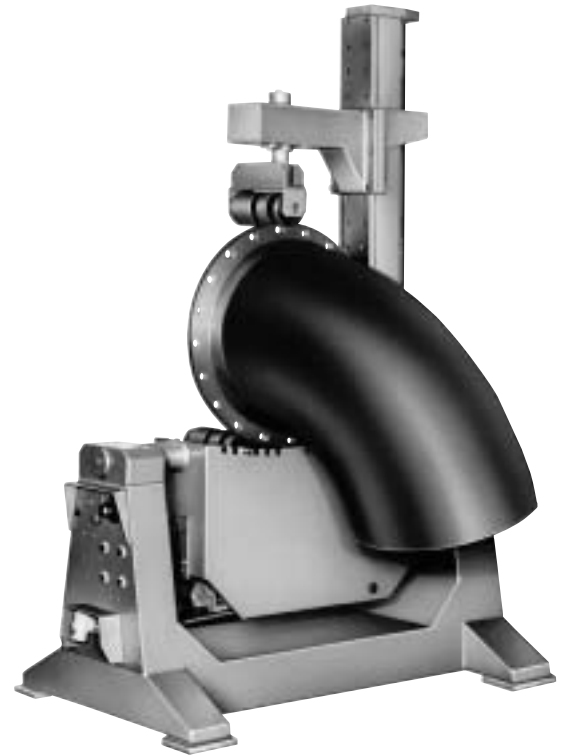

Technical data U 1000:

Rotary speed: infinitely variable 0 - 130 cm/min. Pipe range with clamped pipe: 25 - 800 mm incl. component flange.

Pipe range with unclamped pipe: 30 - 2000 mm (after take out the holding column.)

Max. tilting moment in relation to tilting axis 35 000 cmkg.

Max. load (horizontal pipe): 2 000 kg. Max. load (vertical pipe): 1 000 kg. Torque at drive rollers: 10 000 cmkg.

Power requirement. 2500 VA, 400 V, 3 ph. (other voltae possible).

– We reserve the right to alter specifications without prior notice. –

Electric control:

The rotary speed is set at the front of the machine with the standard version. The direction (right, stop, left) als well as the tilting movement (up, down) are set by remote foot switches.

Accessories for U 1000:

No. 1002 roller support frame to support longer pipes, height adjustable.

No. 1002a set of rubber coated rollers for idler.

No. 1004 face plate 700 x 700 mm to convert the machine into a welding turntable.

No. 1005 holding attachment for a torch (with or without double slide), to be fixed on the pipe rotator. Designet for oxyacetylene cutting and bevelling of pipes as well as for automatic welding of round joints.

No. 1007 1 set of clamps 4, 5, 6, 8, 10, 12, 14, 16, 18, 20, 24, 28, 32 inches. For precise axial location during oxyacetylene cutting.

No. 1007a the same set of clamps in stainless steel.

No. 1008 1 set of rubber coated rollers. For stainless steel, non ferrous and plastic pipes.

No. 1008a set of rubber coated rollers for lobster backs.

No. 1009 set of rollers, usable for stainless stell pipes **and** stainless steel flanges. (material of rollers: stainless steel).

No. 1010 grinding accessory for grinding of weld bevels (only in connection with accessory No. 1007). Includes jig, adjustable to multiple angels, support and angle grinder.

U Range

Models U 150, U 500, U 1000

PIPE ROTATORS WITH CLAMPING ROLLER SYSTEM (patented) The welding device especially designed for pipe welding

Applications:

For clamping, rotation and tilting of pipes with round profiles in manual or automatic welding, mainly in the field of pipe construction (prefabrication and assembly on site) as well as in the manufacture of plant.

Apart from being extremely economical (single handed operation, no interruptions due to repeated turning of the pipe to be welded), this machine also offers improvements in quality – there are no interruptions in the joint and a continually precise horizontal position of the pipe is maintained.

Description:

The electric control as well as the tilting drive are located in the frame. Tilting is carried out manually (U 150 and U 500) or motorized (U 1000, optional U 500) the tilting angle is approx. 180°. The tilting section consists of drive and roller box, holding column, clamping arm and pressure roller. This machine is also available as a non tilting version (designation: U 150H, U 500H, U 1000H). In general, drives and electric controls of the U-series are protected in the frame or in a control panel.

Electric control:

Rotary speed and direction are set at the front of the machine which is switched on and off by a remote foot switch.

Further options of electric control:

- Separate foot operated control unit (see illustration U 500, photo on this page). Switching on and off and changing the direction of rotation takes place by a foot switch, the rotary speed is adjusted by a foot control roller.
- Switching on and off as well as changing the direction of rotation is carried out from the welder's helmet or shield. The rotary speed is set at the machine. Turning direction and turning speed are set on a remote hand pendant.
- Start, stop and change of direction takes place at a manually operated remote control-box. The rotary speed is set at the machine. Turning direction and turning speed are set on a remote hand pendant.



Pipe rotator **Model U 500** (for clamping, rotation and tilting), version B.
This version has an adjustable clamping arm.
The clamping is carried out by an adjustable clamping spindle.
Further technical data are the same as for model U 500, version A (with cotter pin).

U 150

(Universal Welding Device U 150)

PIPE ROTATOR WITH CLAMPING ROLLER SYSTEM (patented) The welding device especially designed for pipe welding

Technical data U 150:

Rotary speed: infinitely variable 0 - 130 cm/min. Pipe range with clamped pipe: 20 - 200 mm incl. component flange. Pipe range with unclamped pipe: 20 - approx. 300 mm (after take out the holding column). Max. tilting moment in relation to axis of tilt:

1500 cmkg. Max. load (horizontal): 300kg on each rotator and roller support frame. Max. load (vertical): 150 kg.

Torque at drive roller: 500 cmkg. Power requirement: approx. 500 VA, 230 V, 1ph. (other voltage possible).

- We reserve the right to alter specifications without prior notice -

Accessories for U 150:

- No 151 base trolley, wheels can be steered and locked in position
- No 152 roller support frame to support longer pipes, height adjustable.
- No 152a set of rubber coated rollers for idler frames.
- No. 154 faceplate 300 i.d. to convert the rotator into a welding turntable.
- No. 155 Holding attachment for torch (with or without double slide), to be fixed to the pipe rotator. Designed for oxyacetylene cutting and bevelling of pipes as well as for automatic welding of round joints.
- No. 156 holding and clamping attachment to weld together pipe bends and pipes with elbows (only in connection with No 154.) For pipe bends up No 100 mm.
- No. 157 1 set of clamps, 4, 5, 6, 8 inches for precise axial location during oxyacetylene cutting.
- No. 157a The same set of clamps in stainless steel.
- No. 158 set of rubber coated rollers, for stainless steel, non ferrous and plastic pipes.
- No. 158a set of rubber coated rollers for labster backs.
- No. 159 set of rollers, usable for stainless steel pipes **and** stainless steel flanges. (material of rollers: stainless steel).



Foot-operated control unit



Pipe rotator Model U 150 on a base trolley, wheels can be steered and locked in position.

PIPE ROTATORS WITH CLAMPING ROLLER SYSTEM (Patented)

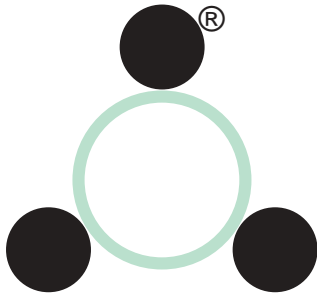

This System can be applied for clamping and rotation of pipes with round profiles, especially in welding.

These machines have essential advantages over traditional devices:

- They can be used for pipes with elbows, tee pieces or other offset loads.
- A wide range of pipes can be clamped. The infinitely variable rotary speed is not affected by the size of a pipe because of its separate drive unit.
- Quick precise centering and clamping without chuck, clamping shoe, etc.
- Flexible pipe handling – pipe can be clamped at its centre of gravity. Tilting moments and supports are irrelevant in most cases.
- It is possible to center two pipes with the same outside diameter.
- Various combinations are possible – e.g. clamping and driving of a main spindle.

Standard models:

model	size of pipe	max load	rotary speed
U 150	20 – 200 mm 1 – 8 inches	300 kg	0 – 130 cm/min
U 150 H	20 – 200 mm 1 – 8 inches	300 kg	0 – 130 cm/min
U 500	20 – 400 mm 1 – 16 inches	1000 kg	0 – 130 cm/min
U 500 H	20 – 400 mm 1 – 16 inches	1000 kg	0 – 130 cm/min
U 1000	25 – 800 mm 2 – 32 inches	2000 kg	0 – 50 cm/min
U 1000 H	25 – 800 mm 2 – 32 inches	2000 kg	0 – 50 cm/min

The U...H models have no tilting mechanism, but apart from that they correspond exactly to the U models.

Description and technical data are the same as the ones for the U models. The accessories of the U...H models are exactly like the U model accessories.

Intermediate sizes and heavier models are available on request.

Some examples for application:

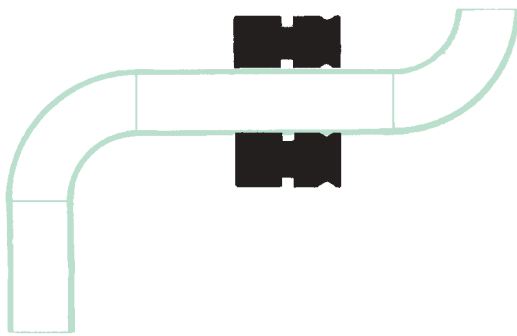

clamping and rotating of a pipe with elbows.

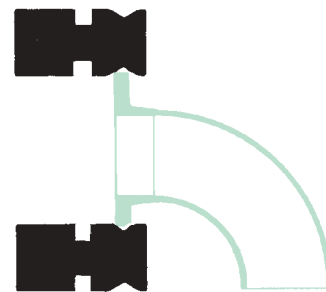

clamping and rotating of a pipe with elbows.

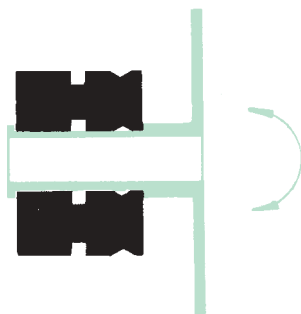

clamping and rotating of a faceplate
(conversion to a tiltable welding turntable).

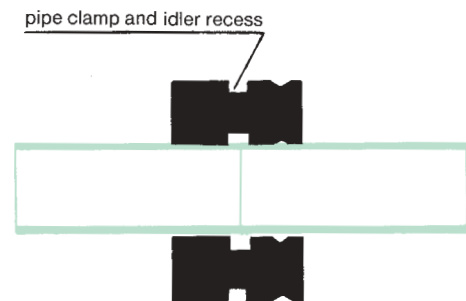

centering clamping and rotating of pipes with the same outside diameter. The pipes can be welded whilst clamped because the joint to be welded is left free by the grooves in the rollers.

**Welding auxiliary tools of every kind such as
turntables – turning tools – pipe welding tools – special welding devices**

U 150

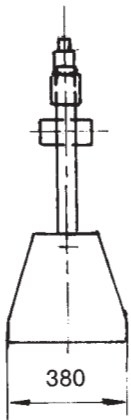

M 1:25

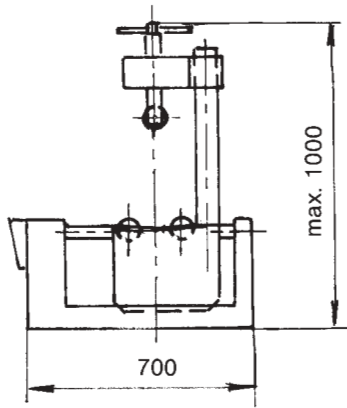

weight approx. 110 kg

U 150 H

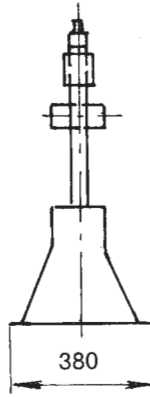

M 1:25

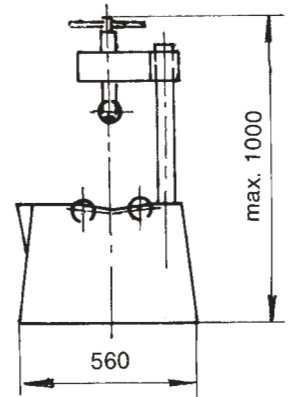

weight approx. 70 kg

U 500

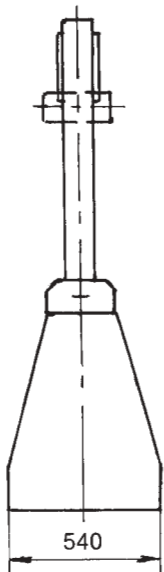

M 1:25

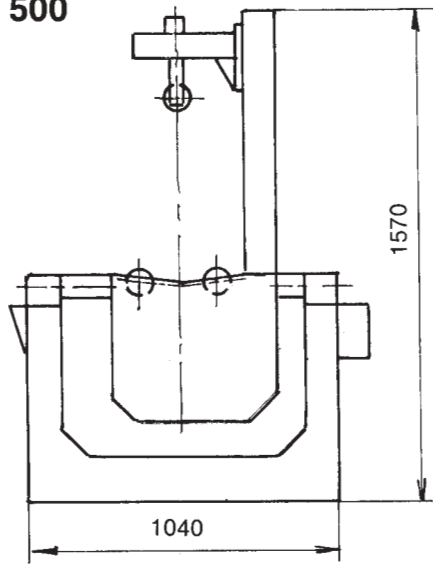

weight approx. 300 kg

U 500 H

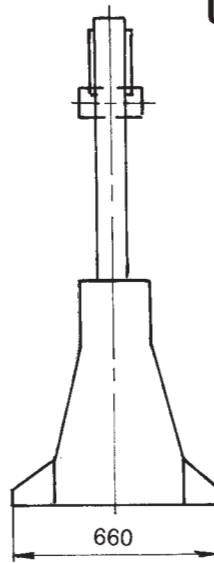

M 1:25

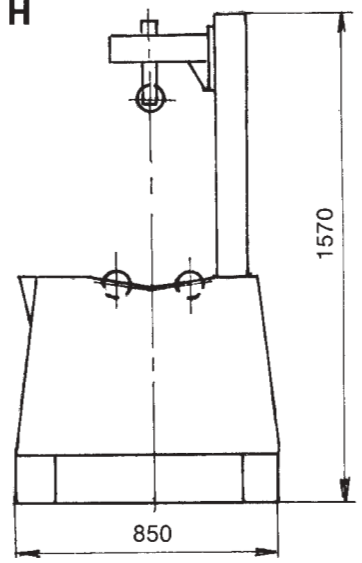

weight approx. 200 kg

U 1000

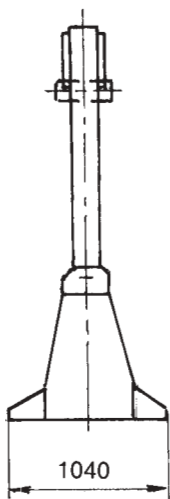

M 1:50

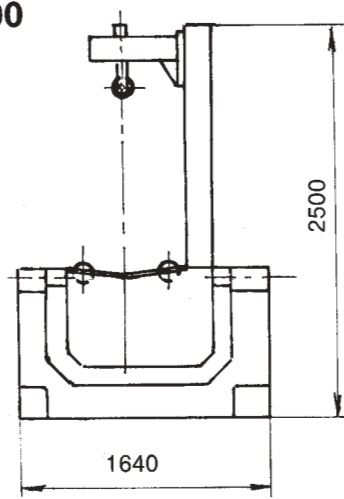

weight approx. 1000 kg

U 1000 H

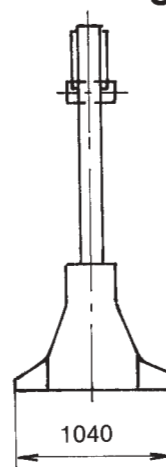

M 1:50

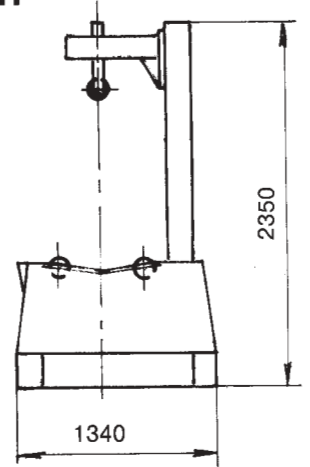

weight approx. 700 kg

Clamping and turning of lobster backs for welding

by means of specially rubberised sets of rollers (No. 158 a, 508 a, 1008 a).

For centralised clamping and rotating of lobster backs, a specially rubberised set of rollers has been developed for each of the 3 different size machines U 150, U 500 and U 1000. These rubberised rollers have larger diameters than those already included in the range (numbers 158, 508, 1008). They may be adjusted axially and can be halved for especially small segments.

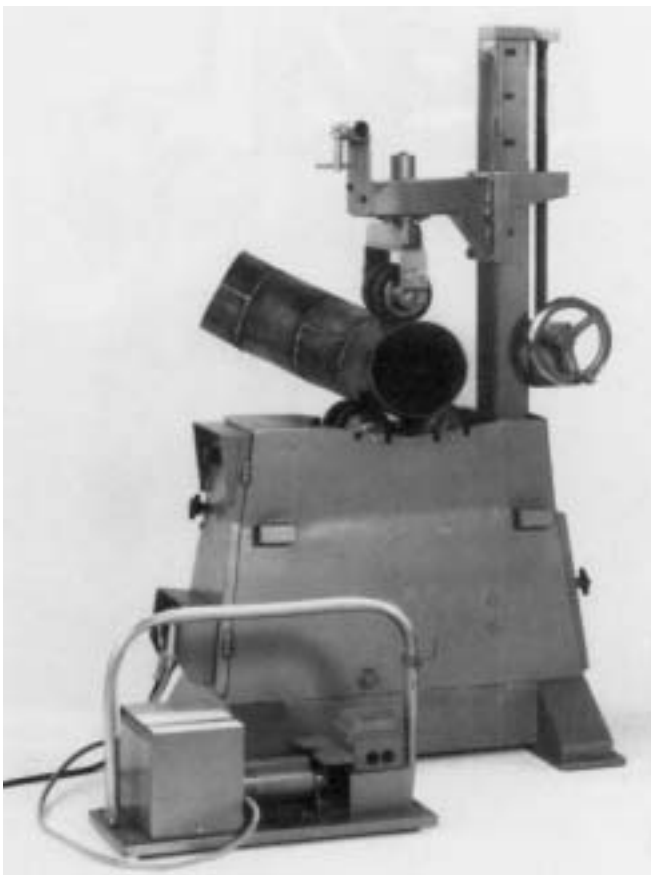

Clamping and rotating of lobster back during circumferential welding using rubberised roller set No. 508 a on a model U 500 H version B machine with separate foot operated control unit.

This accessory has, in addition to the sets of rollers, an extension to the clamping roller housing to accept the large roller diameter. Machines which have already been delivered will also accept this accessory.

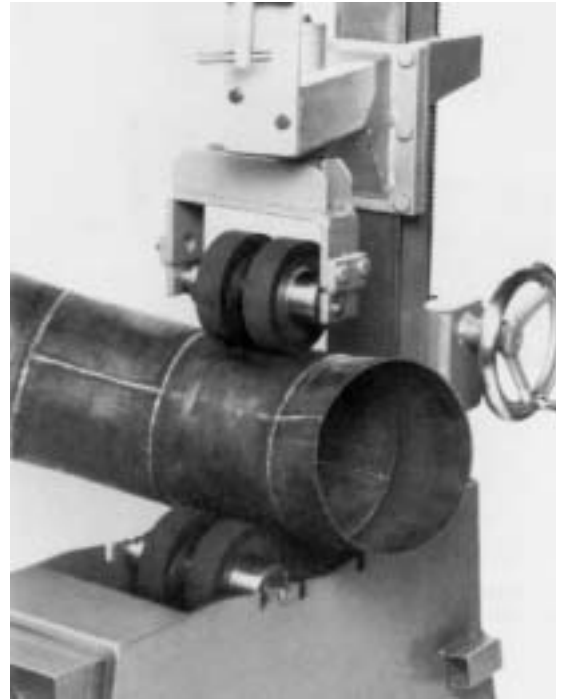

Clamping and rotating of a shallow bend lobster back.

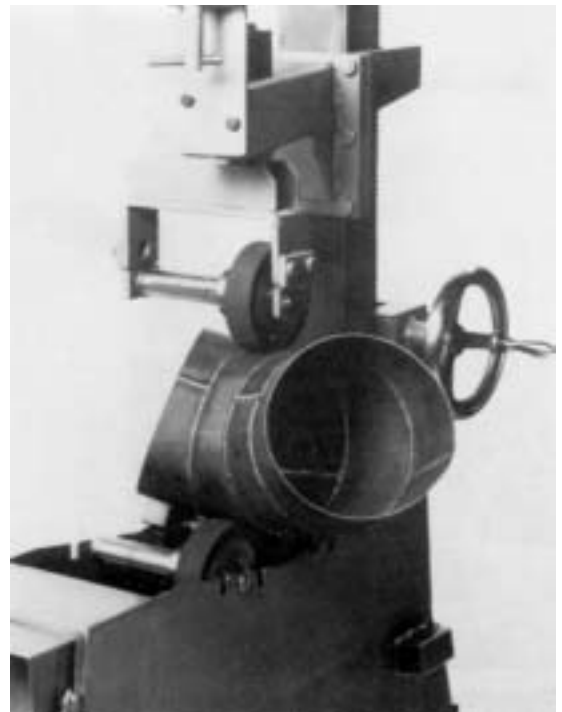

Clamping and rotating of an acute angle lobster back.

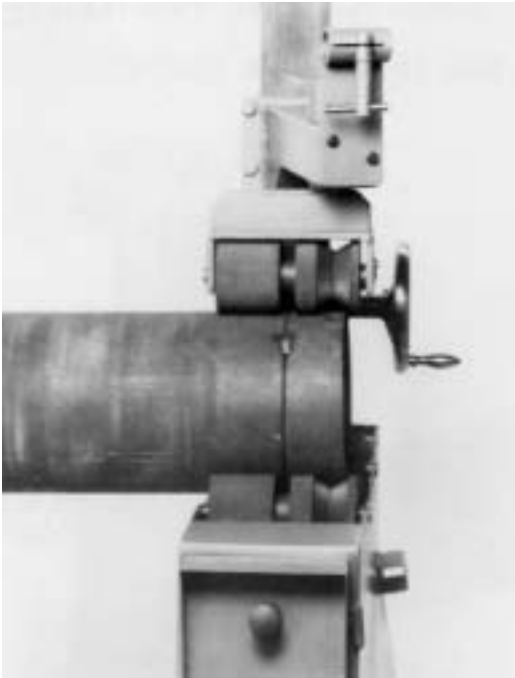

Clamping and rotating assembly for the U-series used as an external alignment device.

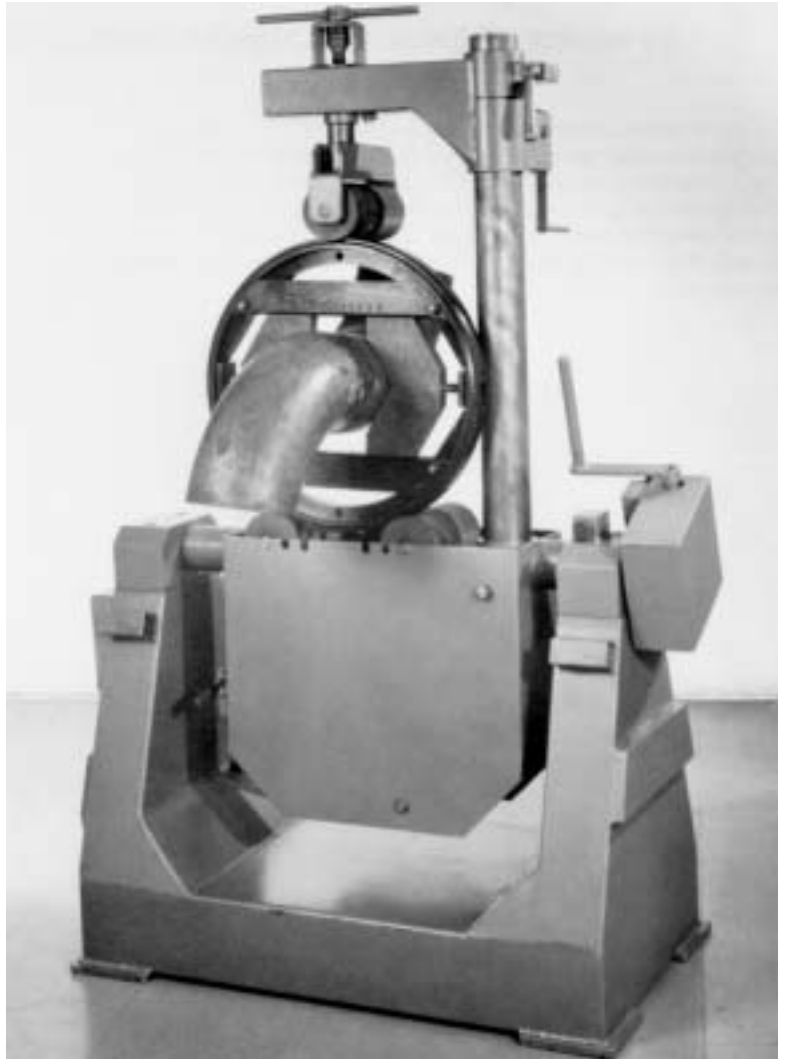

This picture shows accessory No. 506 which is a clamping jig and suitable for welding of pipe bends and acute bend pipes fitted to one of the old versions of clamping, rotating and tilting unit model U 500.

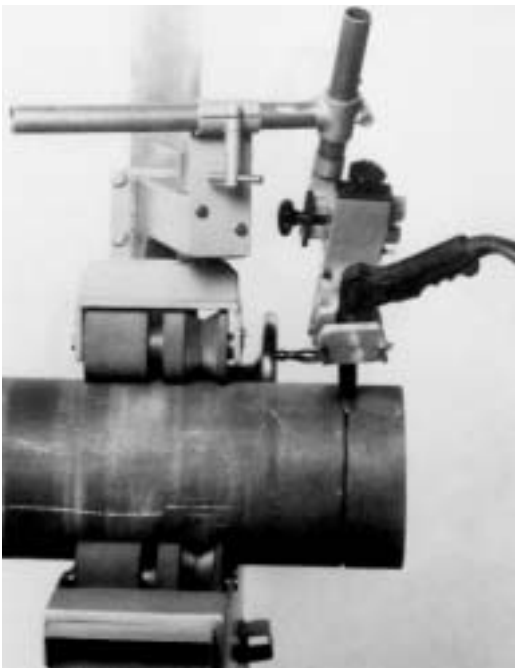

Clamping and rotating assembly model U 500 H, version B, with accessory No. 505 holding attachment with double slide and MIG torch for semi-automatic welding. Adjustment during welding eg for imprecisely cut pipes. (newest design).

U 1000 with roller support frame. Grinding of a welding bevel.

